

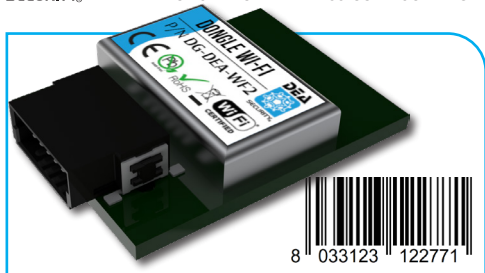

# DATASHEET DG-DEA-WF2

## A03PRO/SPCPRO

SECURITY. Wi-Fi DONGLE FOR WIRELESS CONFIGURATION



P/N **DG-DEA-WF2**

### DESCRIPTION

DG-DEA-WF2 Wi-Fi Dongle enables the wireless functionality of BR-A03P-Z4 board and SPC-PRO sensors (SN-SPCP-FDR1/SN-SPCP-FDR1M and SN-SPCP-FWL1), allowing their configuration/calibration via the related APPs (SW-A03P-APP or SW-SPCP-APP) for IOS/Android mobile devices. The Dongle has been designed to be used by the installer only during service operations (calibration, parameter configuration, system maintenance).

### PACKAGE CONTENTS

Wi-Fi dongle (DG-DEA-WF2) and datasheet.

### CONNECTION

The connection of the dongle takes place via the dedicated connector and it is signalled by the lighting of a specific LED:

- LED DS14 on BR-A03P-Z4 board;
- LED DS4 on the above mentioned SPC-PRO sensors.

**WHEN THE DONGLE IS CONNECTED TO THE PROCESSING BOARD, THE GENERAL TAMPER RELAY OF THE BOARD IS ACTIVE (LED OUT9 LIT).**

**ONLY ONE DEVICE (SMARTPHONE OR TABLET) CAN BE CONNECTED AT A TIME. SHOULD YOU WISH TO USE ANOTHER DEVICE IN SUBSEQUENT CONNECTIONS, POWER OFF / ON THE BOARD OR THE DETECTOR AND DISCONNECT THE WI-FI FROM THE DEVICE. ONCE RECONNECTED VERIFY THAT THE IP ADDRESS OF DEASECURITY WI-FI IS 192.168.5.2**

Before connecting to the DEA Security Wi-Fi network, we recommend downloading the A03PRO APP or SPCPRO APP installing it on your device.



**REFERENCES TO DOWNLOAD THE SPECIFIC APP ARE AVAILABLE IN THE RELATED DATASHEET (BR-A03P-Z4, SN-SPCP-FDR1/FRD1M, SN-SPCP-FWL)**

### WI-FI CONNECTION

- Enable the Wi-Fi function on the device used.
- Connect to the network with SSID "DEA SECURITY" using "DEA123456" password;



### COMPLIANCE

In combination with BR-A03P-Z4, SN-SPCP-FDR1, SN-SPCP-FDR1M, SN-SPCP-FWL1:

- DIRECTIVE 2014/30/EU (EMC)**
  - EN 50130-4:2011
  - EN 61000-6-3:2007+A1:2011
- DIRECTIVE 2011/65/EU (ROHS)**
  - EN 50581:2012
- DIRECTIVE 2014/53/EU (RED)**
  - EN 301 489-17
  - EN 300 328
- WI-FI CERTIFIED™ B, G, N**
- WPA™ – ENTERPRISE, PERSONAL**
- WPA2™ – ENTERPRISE, PERSONAL**



### TECHNICAL DATA

- DIMENSIONS:** 21 x 31 x 9 mm (L x H x D)
- GROSS WEIGHT:** 8 g
- NET WEIGHT:** 4 g
- POWER SUPPLY:** by means of BR-A03P-Z4 board or SN-SPCP-FDR1, SN-SPCP-FDR1M or SN-SPCP-FWL1 detectors
- OPERATING TEMPERATURE:** -25 °C ÷ +70 °C
- RELATIVE HUMIDITY:** <95% non condensing
- AUTHENTICATION WI-FI:** WPA/WPA2
- STANDARD:** IEEE 802.11 b/g/n Wi-Fi

### DIMENSIONAL SCHEME

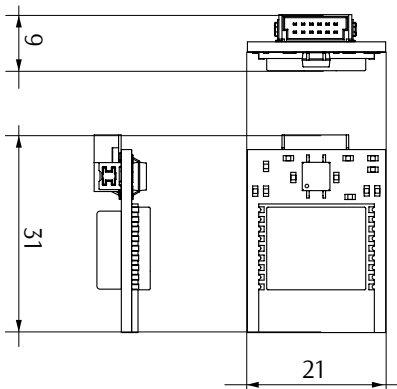

DEA



SECURITY®

Δ03PRO/5PCPRO

DATASHEET

DG-DEA-WF2

**DEA Security S.r.l.**

Via Bolano, snc - 19037 Santo Stefano di Magra (SP) - tel. +39 0187 699233 - fax +39 0187 697615

VAT NO.: IT00291080455

[www.deasecurity.com](http://www.deasecurity.com) - [dea@deasecurity.com](mailto:dea@deasecurity.com)

© 2024 DEA Security S.r.l. - Edition January 2024 - v. 1.0.5.

DEA Security srl reserve the right to change at any time and without notice the features of its products.



SCAN ME